

GORDON

design Corrado Dotti

SUSPENSION LAMP Ø12 **561.71** | **561.75**



Struttura in metallo verniciato a polveri epossidiche con asta telescopica. Cono realizzato in metallo verniciato a polveri epossidiche o lavorato tramite trattamento galvanico con snodo rotabile a 270°. Diffusore in metacrilato.

Metal structure coated with epoxy powders with telescopic rod. Cone made of epoxy powders coated metal or worked by galvanic treatment with 270° rotatable joint. Methacrylate diffuser.

DESCRIPTION and LIGHT SOURCE

561.71 ceiling

lamping: 1 x max 10W - E14 220/240V

dimmiability: according to bulb

dimensions: Ø 12 H. 27 D. 20 cm

note: adjustable direct light 270°

CE Ⓢ IP40

561.75 ceiling recessed

lamping: 1 x max 10W - E14 220/240V

dimmiability: according to bulb

dimensions: Ø 12 H. 25 D. 18 cm

note: adjustable direct light 270°

CE Ⓢ IP40

●● C2 Matt black + C2 matt black

●● C2 Matt black + C41 brushed brass

●● C2 Matt black + C44 polished gold 24KT

●● C2 Matt black + C48 black chrome

DIMENSIONS

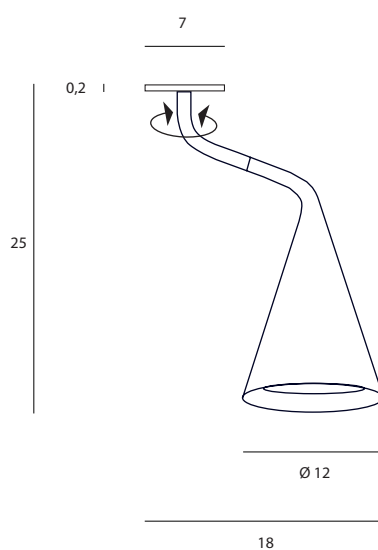
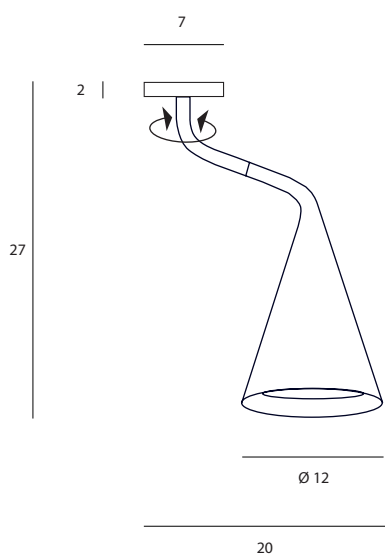

SURFACE FINISHES

Verniciatura a polveri poliestere elettrostatica ad alta estetica con spessore di 80μ cottura in forno a temperatura di 180° per 20 minuti, prova di aderenza: nessun distacco ISO 2409, nebbia salina 300 h 1 mm di penetrazione sulla croce.

Coating with high-aesthetic electrostatic polyester powder with a thickness of 80μ cooking in the oven at a temperature of 180° for 20 minutes, proof of adherence: no detachment ISO 2409, salt spray 300 h 1 mm penetration on the cross.

CONFORMITY

La ditta Gibas s.r.l. dichiara sotto la propria responsabilità che il prodotto al quale questa dichiarazione si riferisce, è conforme, alle seguenti norme/altri documenti normativi/specifiche: EN 60598-2-1:1989 in unione con EN 60598-1:2015-01 e quindi rispondente ai requisiti essenziali delle direttive 2014/35/UE - 2011/65/UE - 2010/30/UE - 2009/125/CE